

TANNOY®



HTS

Owner's Manual

CONTENTS

- 1 **WARRANTY**
- 2 **HTS SET UP GUIDE**
- 3 **ASSEMBLING THE TOWER SPEAKERS (HTS 201)**
- 4 **ASSEMBLING THE CENTRE & SATELLITE (HTS 101) WALL BRACKETS**
- 5 **POSITIONING THE HTS SPEAKERS**
- 6 **CONNECTING THE HTS SPEAKERS TO YOUR A/V RECEIVER OR AMPLIFIER**
- 7 **GRILLES**
- 8 **CARE OF CABINET**
- 9 **TECHNICAL SPECIFICATIONS**

1 WARRANTY

This equipment has been produced and tested with care and precision. It is built to give first class service and carries a 5 year warranty. If the equipment proves to be defective within this period for any reason other than accident, misuse, unauthorised modification or fair wear and tear, Tannoy will repair any such defect or, at our option, replace it without charge for parts, labour or return carriage. This warranty is given in addition to the customer's statutory rights.

Please register your Tannoy product online at www.tannoy.com

If you suspect a problem with your loudspeaker, please contact your local Tannoy dealer who will be able to advise on appropriate action. If you require further assistance, then we ask you to deal directly with your local Tannoy distributor. If you cannot locate your distributor, please contact us directly:

Customer Services, Tannoy Ltd., Rosehall Industrial Estate, Coatbridge, North Lanarkshire, ML5 4TF, Scotland

Telephone: 01236 420199 (National)
+44 1236 420199 (International)

Fax: 01236 428230 (National)
+44 1236 428230 (International)

Email: enquiries@tannoy.com

DO NOT SHIP ANY PRODUCT TO TANNOY WITHOUT PREVIOUS AUTHORISATION

2 HTS SET UP GUIDE

This high performance Tannoy loudspeaker system has been built and tested with care and precision to provide first class performance and reliable operation. To ensure maximum benefit from ownership and for reasons of safety, please read through all the information in this owner's manual before operating and using this system for the first time. Tannoy HTS systems are primarily designed for use with the following equipment:-

- An AV or Home Cinema Receiver with integral 5.1 decoder, 5 power amplifiers and a dedicated LFE or subwoofer line level output.
- An integrated DVD player with 5.1 decoder, 5 power amplifiers and a dedicated LFE or subwoofer line level output.
- A 5.1 decoder (with LFE or subwoofer output) feeding 5 separate power amplifiers. A 5.1 decoder separates digital audio signals from DVD, CD or Digital Broadcast sources into five separate audio channels which feed the five separate speakers in the HTS system and a sixth channel which feeds an HTS subwoofer. Each speaker provides a separate function. The functions are:
- Centre Speaker which carries most of the dialogue or solo performances.
- Front Left and Front Right Speakers which carry special effects and left/right stereo information.
- Left Rear and Right Rear Speakers which carry special effects information.

In addition, the HTS subwoofer provides very low frequency sounds and special effects. The subwoofer supports low frequencies for all 5 audio channels. Please refer to the separate Owner's Manual provided with the subwoofer for full instructions.

3 ASSEMBLING THE TOWER SPEAKERS (HTS 201)

- Fit the bases to each tower speaker using the 3 screws located in the accessory bag. Fit the screws loosely by locating them in the threaded inserts before tightening them all securely.
- Screw the 4 spikes into the threaded inserts on each tower base. Spike locating cups are provided in the accessories pack and these may be used to protect sensitive floor surfaces. Alternatively, self adhesive feet are provided for hard floor surfaces.

4 ASSEMBLING THE CENTRE & SATELLITE (HTS 101) WALL BRACKETS

Fit the wall brackets to the smaller satellite speakers if you wish to wall mount them, as follows:

- Locate the appropriate screws and lock washers in the accessory pack - 2 screws for each wall bracket.
- Locate the Allen key tool which you will use to tighten the hex socket head screws.
- Each wall mounting bracket has two halves and a long screw/ pin which holds the two halves together to act as the hinge. One half is mounted on the speaker using 2 screws and the other half is mounted on the wall using suitable screws and wall plugs. It is your responsibility to ensure that the wall and the screw fixing method are both strong enough to support the weight of the satellite speakers. See the specification page for weights.
- Separate each bracket into two halves by removing the long hinge screw.

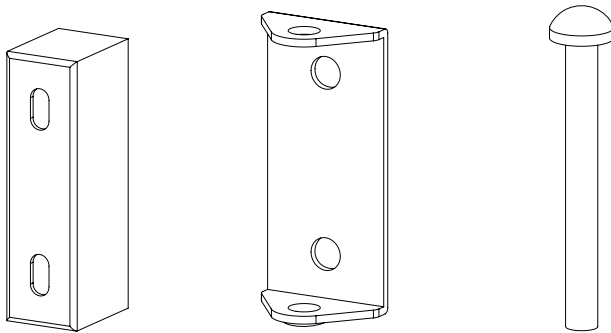

- Fit one half of the bracket with the large holes to the speakers using the screws and lock washers provided. The threaded hinge pin hole in the bracket should face the terminals on the back of the speaker. Fit the other half of the bracket to the wall using a suitable fixing method for the type of wall material- seek professional advice if unsure

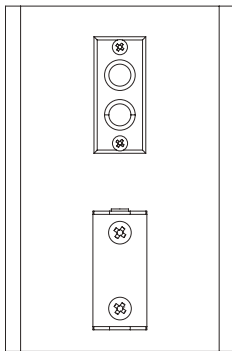

- Fit one half of the bracket to the centre speaker with the threaded hinge pin hole in the bracket facing the top of the cabinet. This orientation will allow the hinge pins to be fitted from the underside of the cabinet when mounting to the wall. Fit the other half of the bracket to the wall using a suitable fixing method for the type of wall material- seek professional advice if unsure

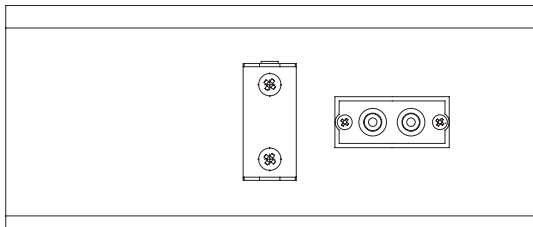

- Position the satellite or centre speaker (with half the wall bracket(s) fitted) against the other half of the wall bracket already fitted to the wall. Line up the brackets so that the long screw pin can be inserted vertically from below the satellite or centre speaker and screwed up lightly. The speakers will now swing in the horizontal plane for best aural and visual effect. Tighten the long screw/ pin to finish.
- To remove the speakers from the wall to access the wiring terminals, remove the long screw/ pin whilst carefully supporting the weight of the speaker.
- Alternatively, self adhesive feet are provided for shelf mounting.

5 POSITIONING THE HTS SPEAKERS

Place the speakers in positions relative to the viewing screen in your room as follows:

- Centre speaker close to, and either above or below the screen.
- Front Left speaker 1 to 2 metres (approximately 3 to 6 foot) to the left of the screen.
- Front Right speaker 1 to 2 metres to the right of the screen. Try to get all 3 front speakers to be in the same plane- the same distance from the viewing position and at least 300mm (12 inches) away from any back wall which may be present behind the screen. Left Rear speaker 1 to 2 metres behind the viewing position and to the left.
- Right Rear speaker 1 to 2 metres behind the viewing position and to the right. Viewed from above, Front Left, Front Right, Left Rear and Right Rear speakers should form a rectangle with the viewing position in the centre of the rectangle.
- Place the subwoofer on the floor alongside the wall nearest to the screen. The exact position isn't critical and can be adjusted once the system is up and running. Refer to subwoofer Owner's Manual.

DO NOT PLACE THE SUBWOOFER CLOSER THAN 1 METRE (3 FOOT) FROM A VIEWING SCREEN USING A CATHODE RAY TUBE. This warning does not apply to Plasma and LCD screens.

This is an ideal positioning set-up, in practice there will be inevitable compromises depending on your room layout and the furniture within it. Refer to your decoder or AV Home Cinema receiver instructions for further advice in compensating for non-ideal situations.

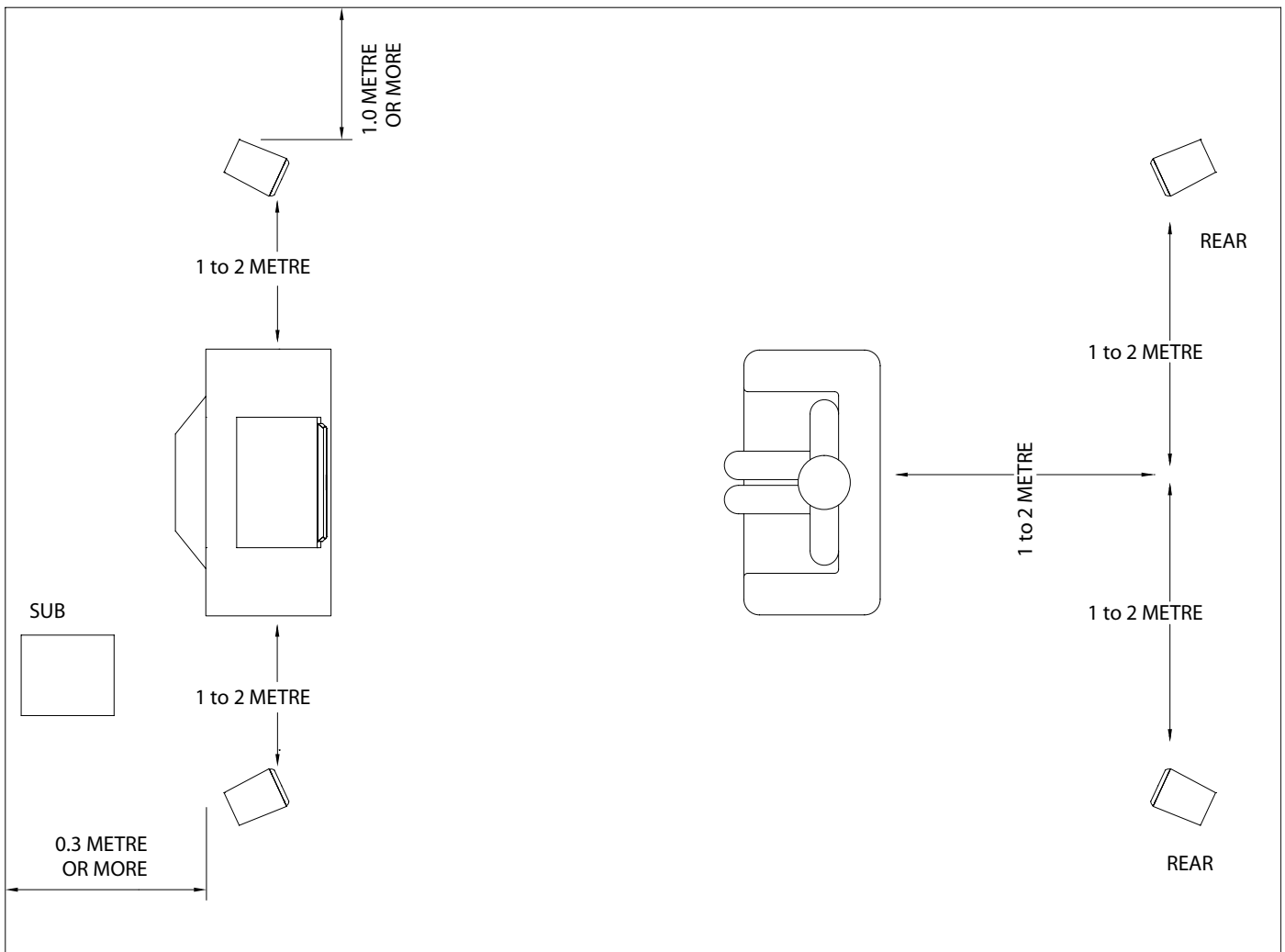

6 CONNECTING THE HTS SPEAKERS TO YOUR AV RECEIVER OR AMPLIFIER

Connect the speakers to the AV Home Cinema receiver or separate amplifier terminals as follows:

- Measure out suitable lengths of cable, to reach between the speakers and your AV or Home Cinema receiver speaker output terminals.
- Wire up the system connecting each speaker to the appropriate terminals on the receiver or amplifier making quite sure that cables connect red to red terminals (+ to +) and black to black terminals, (- to -). Take care to distinguish between left and right channels, and the front and rear channels, as seen from the viewing position. This is a very important stage in setting up. Getting things wrong at this stage is the most likely reason for disappointing results when troubleshooting the system.

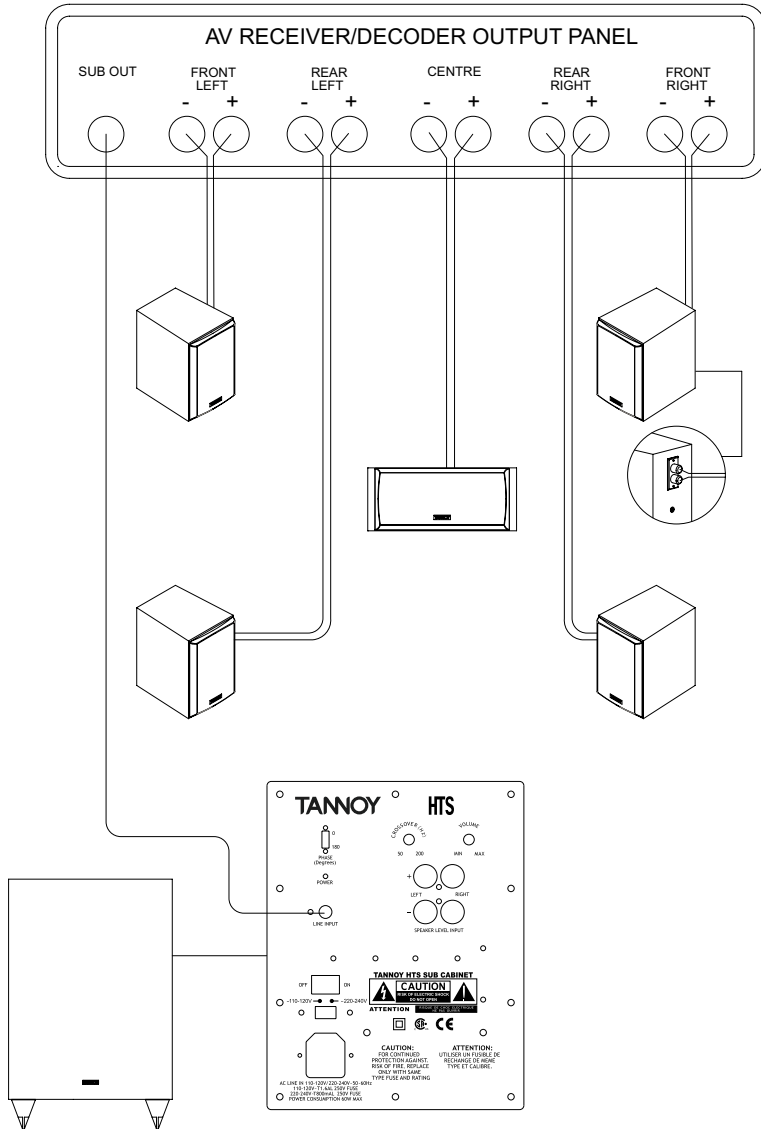

7 GRILLES

The HTS grilles have been designed to provide acoustic transparency. However, for ultimate fidelity the enthusiast will appreciate the slight improvement in clarity and detail that is achieved by removing the grilles during listening.

8 CARE OF CABINET

The cabinets should only be cleaned with a dry cloth or with a light application of quality non-silicone furniture polish.

9 TECHNICAL SPECIFICATIONS

SATELLITE

Recommended amplifier power	25 – 100 Watts (RMS)
Sensitivity (2.82V @ 1m)	87dB
Nominal impedance	8 Ohms
Frequency response (-6dB)	100Hz – 40kHz
Drivers	HF: 19mm (3/4") titanium WideBand™ dome, with neodymium magnet system LF: 75mm (3") paper cone
Crossover Frequency	3kHz (LF to HF)
Magnetic shielding	Yes
Weight	1.4kg (3.1lbs)
Dimensions (H x W x D) (including grille)	160mm x 106mm x 142mm (6.3" x 4.2" x 5.6")
Supplied accessories	Wall bracket, self adhesive feet

CENTRE

Recommended amplifier power	25 – 100 Watts (RMS)
Sensitivity (2.82V @ 1m)	87dB
Nominal impedance	6 Ohms
Frequency response (-6dB)	100Hz – 40kHz
Drivers	HF: 19mm (3/4") titanium WideBand™ dome, with neodymium magnet system LF: 2 x 75mm (3") paper cone
Crossover Frequency	3kHz (LF to HF)
Magnetic shielding	Yes
Weight	2.3kg (5.1lbs)
Dimensions (H x W x D) (including grille)	106mm x 250mm x 166mm (4.2" x 9.8" x 6.6")
Supplied accessories	Wall bracket, self adhesive feet

TOWER

Recommended amplifier power	25 – 100 Watts (RMS)
Sensitivity (2.82V @ 1m)	88dB
Nominal impedance	6 Ohms
Frequency response (-6dB)	80Hz – 40kHz
Drivers	HF: 19mm (3/4") titanium WideBand™ dome, with neodymium magnet system LF: 2 x 75mm (3") paper cone
Crossover Frequency	3kHz
Magnetic shielding	Yes
Weight	6.2kg (13.7lbs)
Dimensions (H x W x D) (including grille, without plinth)	904mm x 106mm x 167mm (35.6" x 4.2" x 6.6")
Dimensions (H x W x D) (including grille and plinth)	922mm x 179mm x 225mm (36.3" x 7.1" x 8.9")
Supplied accessories	Floor coupling spikes with floor protective cups, Self adhesive feet

Tannoy United Kingdom	T: 00 44 (0) 1236 420199	E: enquiries@tannoy.com
Tannoy Deutschland	T: 00 49 (180) 1111 881	E: anfragen@tannoy.com
Tannoy Middle East	T: 00 971 (04) 4401208	E: enquiries@tannoy.com
TCIGroup International	T: 00 45 8742 7000	E: info@tcgroup-international.com
TCIGroup Americas	T: 00 1 (519) 745 1158	E: info@tcgroup-americas.com

Tannoy adopts a policy of continuous improvement and product specification is subject to change.



6481 0566 / 0811

tannoy.com